



XP95 Multisensor Detector

▲ Part Number 55000-885

## OPERATING PRINCIPLES

The XP95 multisensor detector contains an optical smoke sensor and a thermistor temperature sensor whose outputs are combined to give the final analogue value.

The multisensor construction is similar to that of the optical detector but uses a different lid and optical mouldings to accommodate the thermistor temperature sensor. The sectional view (Fig.16) shows the arrangement of the optical chamber and thermistor.

The signals from the optical smoke sensing element and the temperature sensor are independent, and represent

the smoke level and the air temperature respectively in the vicinity of the detector. The detector's microcontroller processes the two signals. The temperature signal processing extracts only rate of rise information for combination with the optical signal. The detector will not respond to a slow temperature increase - even if the

temperature reaches a high level. A large sudden change in temperature can, however, cause an alarm without the presence of smoke, if sustained for 20 seconds.

The processing algorithms in the multisensor incorporate drift compensation.

The sensitivity of the detector is considered the optimum for most general applications since it offers good response to both smouldering and flaming fires.

Note: in situ testing of the multisensor should be carried out as for smoke detectors.

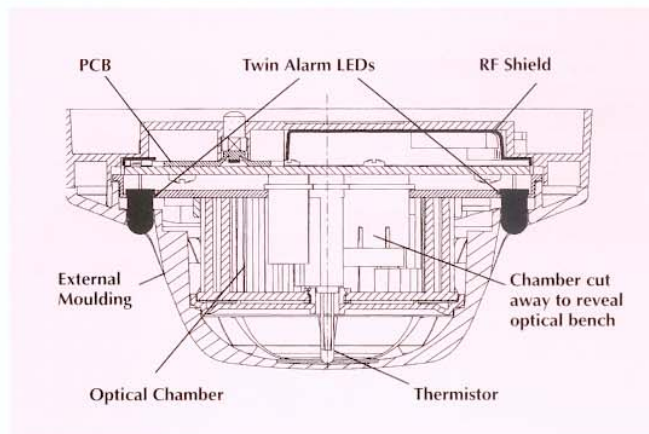

Fig.16 Sectional view - XP95 Multisensor Detector